

수냉식 양면 스포트 용접기  
Spot WelderModel No.  
SY-SW22000SLIM

## Specifications

제품명	수냉식 양면 스포트 용접기
모델명	SY-SW22000SLIM
입력전압	상상 AC380V, 50/60Hz (220V 옵션 선택 가능)
냉각방식	수냉식
용접방식	DC저항용접 리니어방식
최대전류	16000A
정격용량	15KW
용접두께	3+3+3+3(mm)
용접용량설정	3단
용접시간설정	10단, 최대 용접 시간 1초
용접유형	양면, 단면, 와샤, 시보리, 반복, 자동함마
양면용접건	타입-C건, 케이블-공냉, 200SQ, 2.5m (X건 옵션 제작)
단면용접건	타입-권총형, 케이블-150SQ, 2.5m
어스선케이블	150SQ, 2.5m
압축공기압력	8Kgf/cm <sup>2</sup>
전극파워	550daN
제품크기	(W)430 x (L)650 x (H)1140mm (지지걸이포함높이: 2110mm)
공급액세서리	양면용접C건(X건 옵션), 단면용접건, 지지걸이, 메인스프링발란스(15kg), 보조스프링발란스(5kg), 자동함마, 수동함마, 양면용접팁, 단면용접팁 3종(총알팁, 와샤팁, 시보리팁), 양면 C 웰딩암 특대, 대, 중, 소, C-X 웰딩암, 붐높이조정용 리모컨과 전동 실린더

Product name	Water-cooled spot welder
Model No.	SY-SW22000SLIM
Input voltage	3Phase AC380V, 50/60Hz (220V-Option)
Cooling type	Water cooling
Welding principle	Linear type DC resistance spot welding
Max. welding current	16000A
Rated power	15KW
Max. Welding thickness	3+3+3+3(mm)
Adjustable welding capacity	3steps
Adjustable welding time	10 steps, Maximum weld time 1sec
Welding mode	Double-sided weld, Single-sided weld, Pulse weld, Washer weld, Contact shrinking, Dent pulling works
Double-sided welding gun	Type-C Gun, Cable-Air cooling, 200SQ, 2.5m (X Gun: Option)
Single-sided welding gun	Type-Hand gun, Cable-150SQ, 2.5m
Earth cable	150SQ, 2.5m
Working air pressure	8Kgf/cm <sup>2</sup>
Welding electrode power	550daN
Dimension	(W)430x(L)650x(H)1140mm (With overhead boom:2110mm)
Standard accessories	Double-sided welding C gun (X Gun: Option), Overhead boom, Single-sided welding hand gun, Spring balancer(Main:15kg, Sub:5kg), Automatic slide hammer, Dent puller, Double-sided welding electrode, Pointed tip, Washer tip, Contact shrinking tip, C-Welding arm(S, M, L, XL), C-X Welding arm, Remote controller & actuator for lifting boom

**Model No.**

SY-SW22000SLIM

위치조절이 자유로운 붐  
Flexible boom control



리모컨 장치  
Remote control



**The name of each part**

냉각수 호스 Cooling water hose

웰딩암 Welding arm

웰딩암 고정바 Welding arm locker

피스톤 팁 Piston electrode

웰딩암 팁 Welding arm electrode

측면손잡이 Side lever

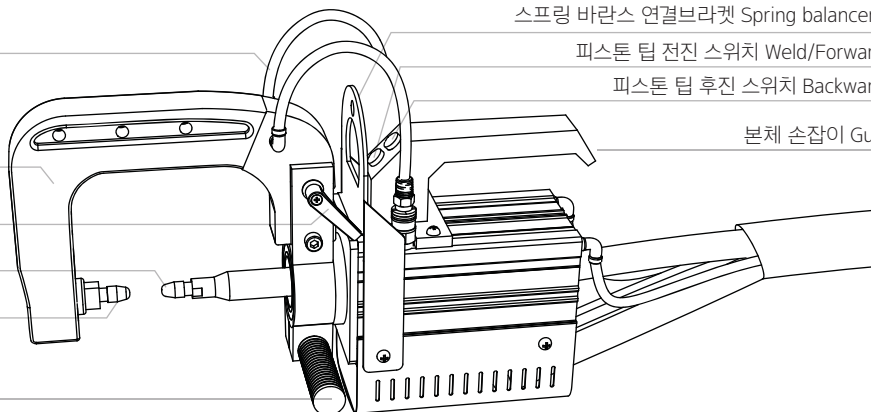

스프링 밸런스 연결브라켓 Spring balancer bracket

피스톤 팁 전진 스위치 Weld/Forward switch

피스톤 팁 후진 스위치 Backward switch

본체 손잡이 Gun handle

Double-sided welding accessories

C건 C-gun

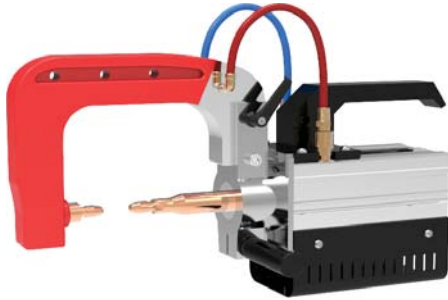

C-X 웰딩암 C-X welding arm



C 웰딩암 C welding arm

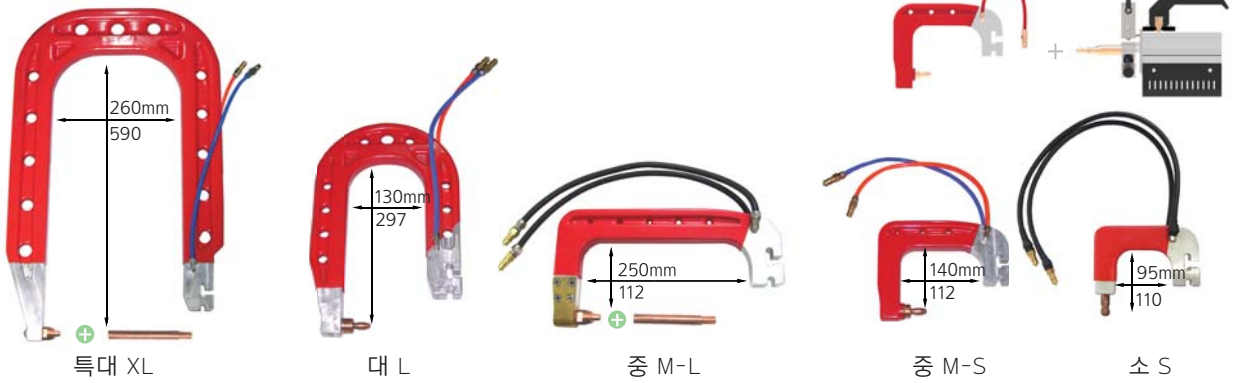

Single-sided welding accessories

단면 용접건  
Single-sided welding gun



팁 세트 Tip set



수동 함마 Rapid puller



Automatic slide hammer

제 품 명	자동 함마
모 델 번 호	SS-101
철 심 두 께	5mm
함 마 길 이	230mm
코 드 길 이	3m
포 장 크 기	(W)160 x (L)665 x (H)80mm
제 품 무 게	5.8kg

Product name	Automatic slide hammer
Model No.	SS-101
The thickness of welding rod	5mm
The length of slide hammer	230mm
The length of cable	3m
Packing dimension	(W)160 x (L)665 x (H)80mm
Weight	5.8kg

